

# T-PAK 550

HIGH SPEED BAG SEALING SYSTEM



The T-PAK 550 Bag Compression and Sealing System is a high quality system for increasing bag handling and sealing output. The combination of a heavy duty conveyor system with a full width compression belt and the Band Supersealer Platform or Hot Air Supersealer Platform makes this an unchallenged heat sealing system for many applications, superior in performance and speed with low maintenance cost.





### TECHNICAL SPECIFICATIONS T-PAK 550:

Electric:	110 VAC, 1 Ph, 60 Hz, 10 Amp or to requirement. 220 VAC, 1 Ph, 50 Hz, 10 Amp.
Finish:	Powder coating standard, stainless steel optional.
Belt length:	12 ft. (3 meters) Other sizes on request.
Belt width:	18" (457mm) Other sizes on request.
Speed:	Variable to match Supersealer.
Feed:	Right to left or left to right.
Standard features:	Product placement on the main conveyor is aided by a guide and bag top guide.
Pneumatic:	Not required for standard configuration.

### TECHNICAL SPECIFICATIONS BAG SEALER:

Bag size range:	Width—all sizes, length up to 30" (762mm).
Bag material range:	Heat sealable materials up to 40 Mils (100 microns).
Speed:	Up to 120 fpm (36.5 meters/min.) belt speed.
Seal width:	1/4" (6mm) to 1/2" (12mm) plain or textured.
Machine handling:	Right to left or left to right.

### FEATURES

### BENEFITS

Supersealer bag sealer.	Superior performance for many years.
Automatic bag presentation.	Optimum seal quality and aesthetics.
Full width compression belt.	Removes excess air from the bags.
Modular design with individual frames on wheels.	Mobility and easy access for maintenance.
Stainless steel construction optional.	Ideal for use in food processing plants and harsh environments.

### T-PAK 550 OPTIONS:

- Bag top trimmers and trim removers.
- Ink jet printers.
- Product detect in seal area.
- T-Pak in-feed.
- Automatic bag loaders.
- Crank stand.

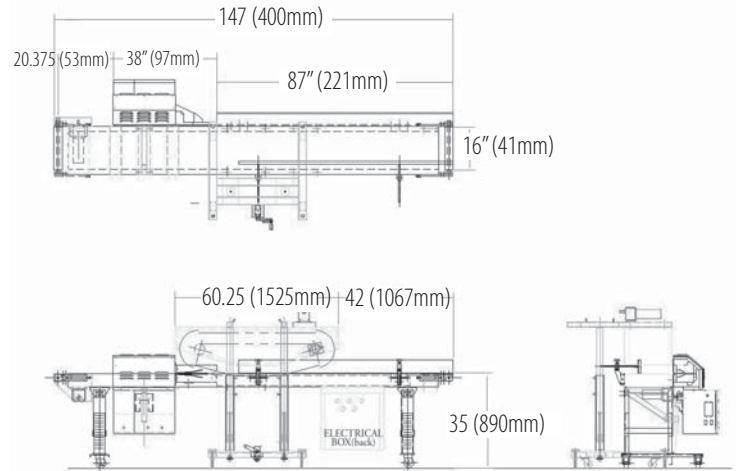

T-Pak 550 machine drawing.



### Our Supersealers seal bags for a variety of industries:

Fruits, nuts, vegetables, meats, poultry, seafood, animal feed, dog & cat foods, bakery goods, snack foods, candy, spices, coffee, tea, chemicals, agricultural products, textiles, general goods.



OK International Corporation  
73 Bartlett Street  
Marlborough, MA 01752  
508-303-8286  
508-303-8207  
sales@oksealer.com