

SUPERSEALER HCA

ROTARY HOT AIR SEALER



The Supersealer HCA High Capacity Hot Air Bag Sealer is a continuous heat sealer designed to meet the most demanding applications. Its stainless steel finish, heavy-duty construction, and increased heat capacity enables sustainable high-speed output for thicker bags. The Supersealer HCA provides consistent worry-free long term reliability for a wide range of tough sealing products. The Supersealer HCA is the only washdown bag sealer on the market.





TECHNICAL SPECIFICATIONS SUPERSEALER HCA:

Bag size range:	All bag sizes.
Bag material range:	Heat sealable materials up to 40 mils. (1000 microns)
Speed:	Up to 120 fpm (36.5 meters/min.) belt speed.
Seal width:	1/4" (6mm) to 1/2" (12mm) plain or textured.
Machine handing:	Right to left or left to right.
Electric:	230/460 VAC, 3 Ph, 60 Hz, 15 Amp or to requirement. 200/400 VAC, 3 Ph, 50 Hz, 15 Amp.
Pneumatic:	80-160 psi clean dry air.



FEATURES

BENEFITS

Stainless steel finish.	Clean and durable.
Hot-air sealing technology.	Optimum seal quality with low maintenance
Variable speed.	Ease of matching conveyor speeds and flexibility.
PID temperature controls.	Accurate and consistent sealing temperature.
Mobile base and gas strut adjustable pedestal.	Bag size change made easy.

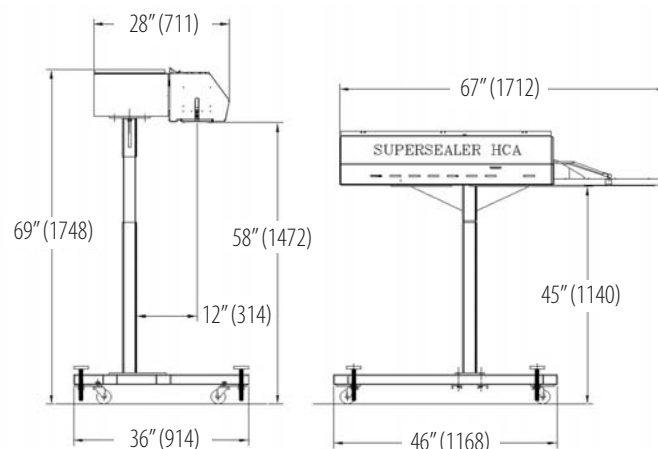

Supersealer HCA machine drawing.

SUPERSEALER HCA OPTIONS:

- Bag top trimmers and trim removers.
- Bag support conveyors.
- Bag coders and printers.
- Scales and Auger fillers.
- Bag top de-duster.
- Crank stand.



Our Supersealers seal bags for many different industries:

Fruits, nuts, vegetables, meats, poultry, seafood, animal feed, dog & cat foods, bakery goods, snack foods, candy, spices, coffee, tea, chemicals, agricultural products, textiles, general goods.

