



# SUPERSEALER SB20 WITH F-206 SINGLE LANE SCALE

OK International's Supersealer SB20 Continuous Heat Bag Sealer continuously seals a wide range of bag materials at high speed and efficiency. The Tridyne Model F-206 (shown above) will run up to 15 dumps per minute, per lane (machine available up to 5 lanes). This is controlled by a state-of-the-art, commercially available Allen Bradley PLC Controller.





Tridyne Systems handle capacities from a few ounces up to 60 pounds, and are fully wash-down capable. The F-206 can be easily interfaced with other packaging machinery such as baggers, indexing conveyors, or case erectors and fills bags, bottles, containers, boxes, and pouches. Tridyne tests your products and sets up all initial parameters before shipping. Simply plug the system in and run. Tridyne also encourages you to visit the factory to take advantage of free machine training prior to shipping.

**TECHNICAL SPECIFICATIONS F-206 SCALE:**

Standard capacities:	From a few ounces to 60 lbs.
Speed:	Up to 15 dumps per minute per lane.
Dimensions:	Varies depending on the number of lanes.
Power requirements:	115 VAC, 60 Hz.
Air requirements:	60 PSIG.
Supply hopper capacity:	From 1.5 cubic ft. to 6 cubic ft.
Construction:	Stainless steel washdown configuration.
Display indicators:	Shows "under", "good" and "over" weight status.
Accuracy:	0.1% of full load (static).
Load cell:	Strain Gauge.
Memory:	Non-volatile, user programmable, up to 50 job sets.
Info display:	6" monochrome LCD display with touch screen.
Shipping weight:	Variable depending on machine.

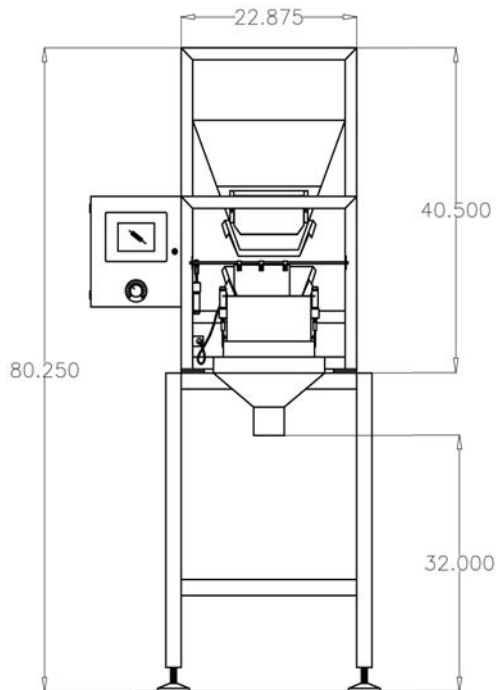

Model F-206 drawing.

**TECHNICAL SPECIFICATIONS SUPERSEALER SB20:**

Bag size range:	All bag sizes.
Bag material range:	Heat sealable materials up to 12 mils.
Speed:	Up to 75 (22 meters/min.) fpm belt speed.
Seal width:	3/8" (7mm).
Machine handing:	Right to left or left to right.
Electric:	110 VAC, 1 Ph, 60 Hz, 10 Amp or to requirement. 220 VAC, 1 Ph, 50 Hz, 10 Amp.
Pneumatic:	Not required for standard configuration.

**FEATURES**

**BENEFITS**

Stainless steel finish.	Clean and durable.
Heavy duty band sealing technology.	Optimum seal quality and performance.
Variable speed.	Ease of matching conveyor speeds and flexibility.
PID temperature controls.	Accurate and consistent sealing temperature.
Mobile base and gas strut adjustable pedestal.	Simple set up and adjustment.

**SUPERSEALER SB20 OPTIONS:**

- Crank stands.
- Bag coders and printers.
- Scales and Auger filler.
- Bag support conveyors.
- Bag top trimmer and trim removers.



**Our Supersealers seal bags for many different industries:**

Fruits, nuts, vegetables, meats, poultry, seafood, animal feed, dog & cat foods, bakery goods, snack foods, candy, spices, coffee, tea, chemicals, agricultural products, textiles, general goods.



Tridyne Process Systems  
80 Allen Road  
South Burlington, VT 05403  
802-863-6873  
802-860-1591  
sales@tridyne.com



OK International Corporation  
73 Bartlett Street  
Marlborough, MA 01752  
508-303-8286  
508-303-8207  
sales@oksealer.com